



**INTERNATIONAL COFFEE ORGANIZATION**  
**WORLD COFFEE CONFERENCE**

*17 - 19 May 2001, Hilton Park Lane, London*

Organised by

**FOLICHTS**

# Total 427 Attendees

- **Standard & early bird delegates** 209
- **ICO free delegate places** 70
- **ICO reduced places** 50
- **Paid sponsor delegates** 21
- **Free sponsor delegates** 36
- **Speakers & Chairs** 41

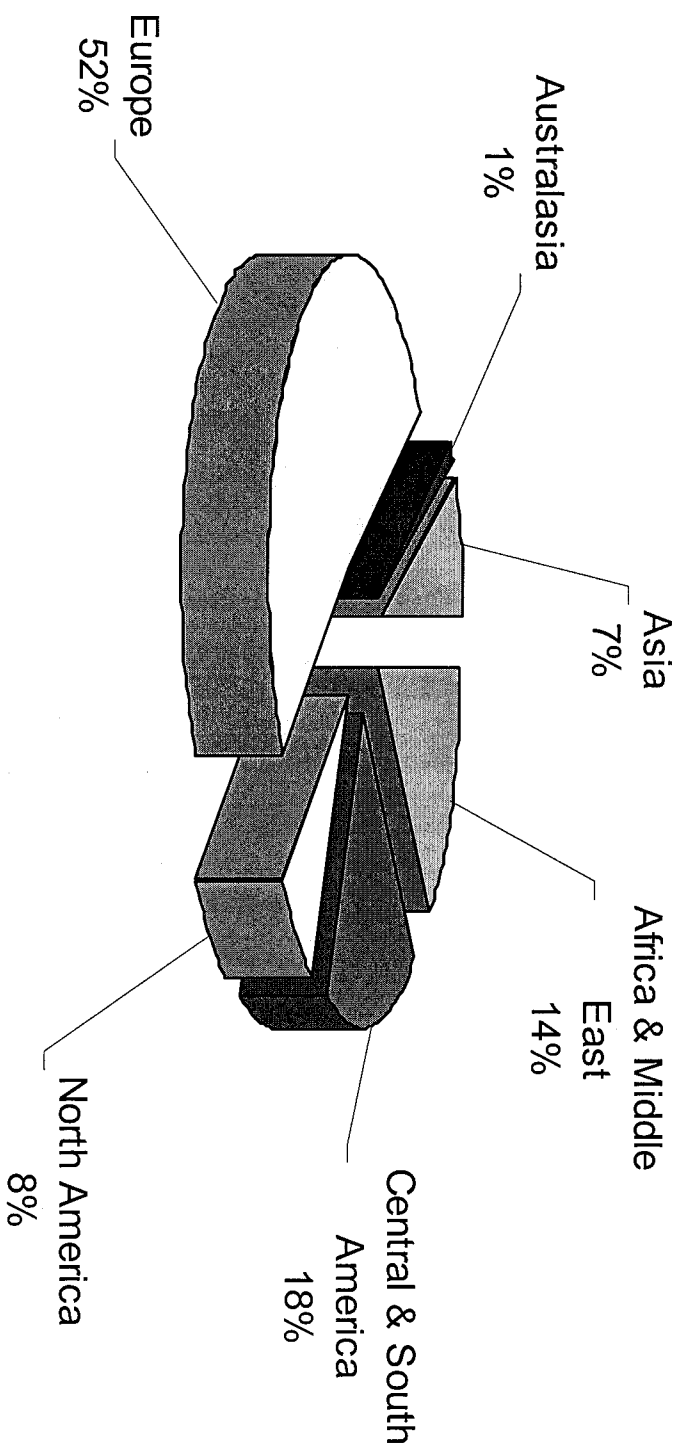

- **Africa & Middle East** 61
- **Central & South America** 76
- **Europe** 221
- **Australasia** 4
- **Asia** 31
- **North America** 34
- **427**

# Attendees from 61 countries

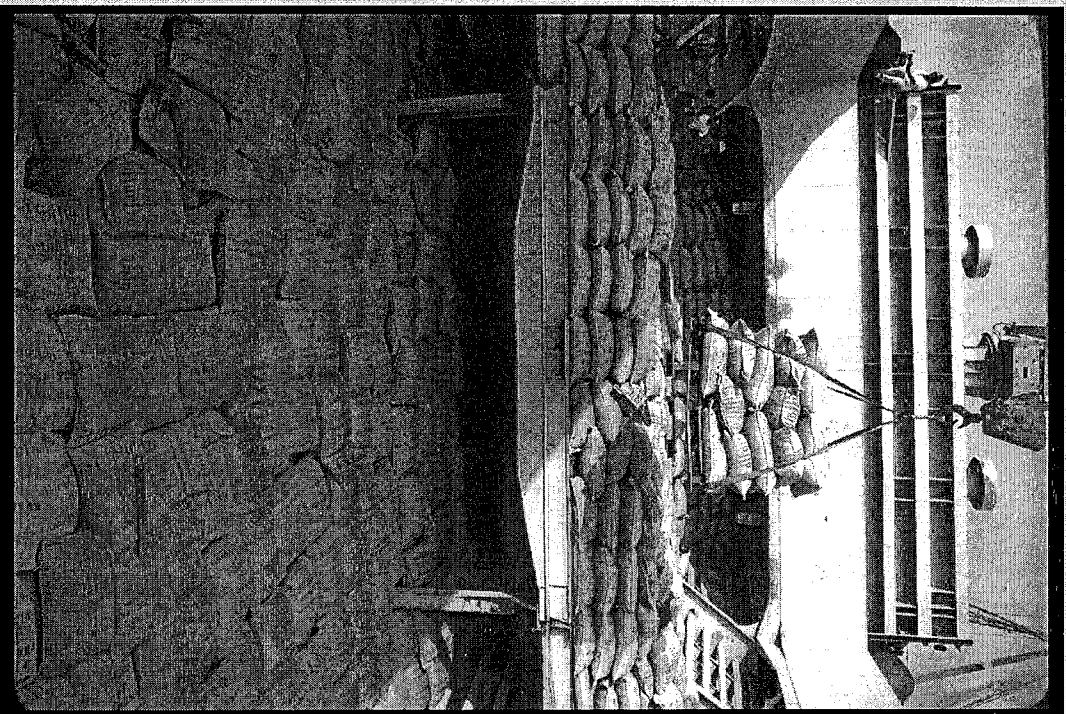

Angola, Argentina, Australia, Belgium,  
Brazil, Bulgaria, Burundi, Cameroon,  
Canada, Central African Republic,  
Colombia, Congo Democratic Republic,  
Costa Rica, Cuba, Denmark,  
Dominican Republic, El Salvador,  
England, Ethiopia, Finland, France,  
Gabon, Germany, Guatemala, Haiti,  
Honduras, Hong Kong, India, Ireland,  
Israel, Italy, Ivory Coast, Jamaica,  
Japan, Kenya, Madagascar, Malawi,  
Mexico, Nicaragua, Nigeria, Norway,  
Panama, Papua New Guinea, Peru,  
Portugal, Russia, Rwanda, Singapore,  
Spain, Sweden, Switzerland, Tanzania,  
Thailand, The Netherlands, Togo,  
Uganda, USA, Vietnam, Zambia,  
Zimbabwe

# Attendees by job title

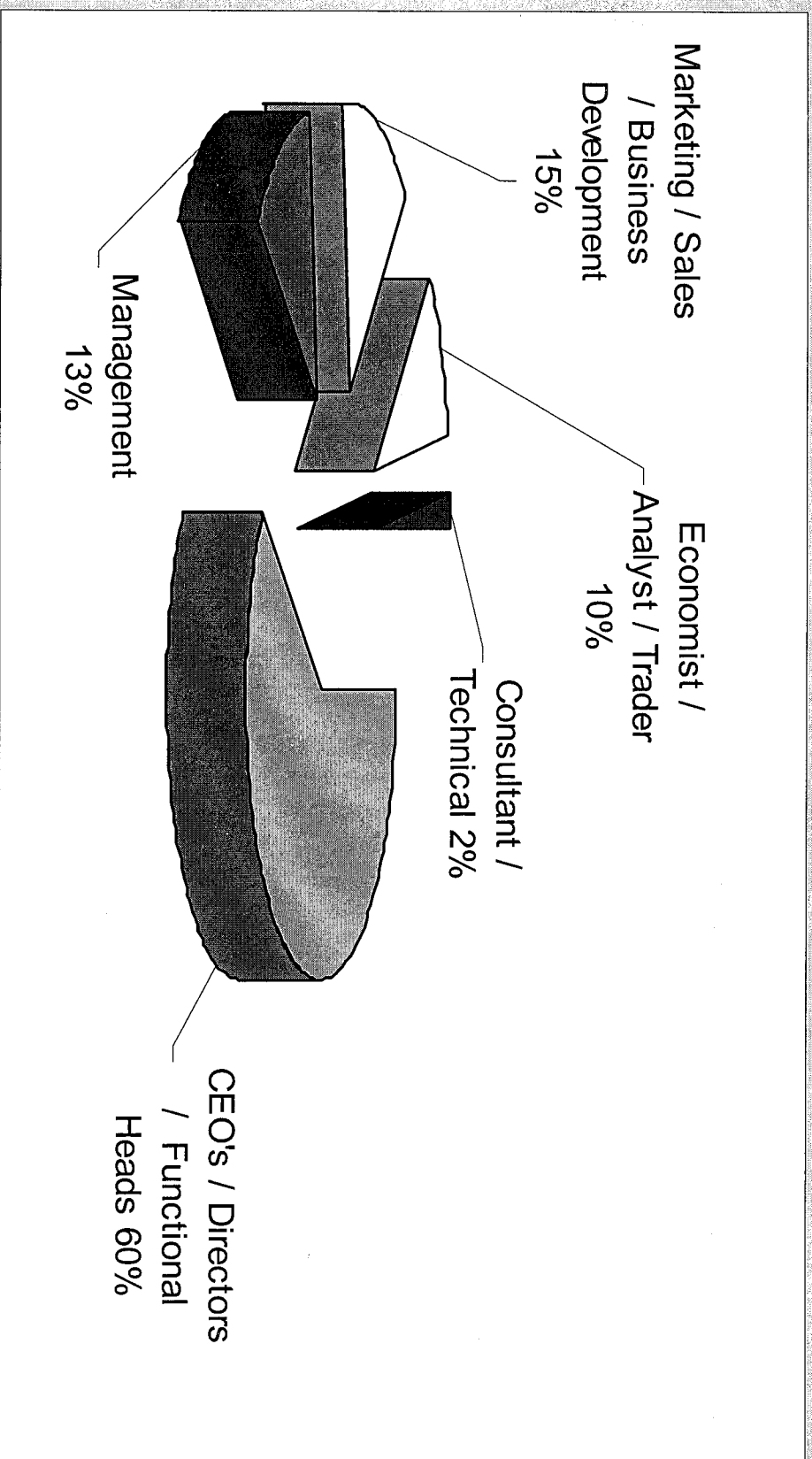

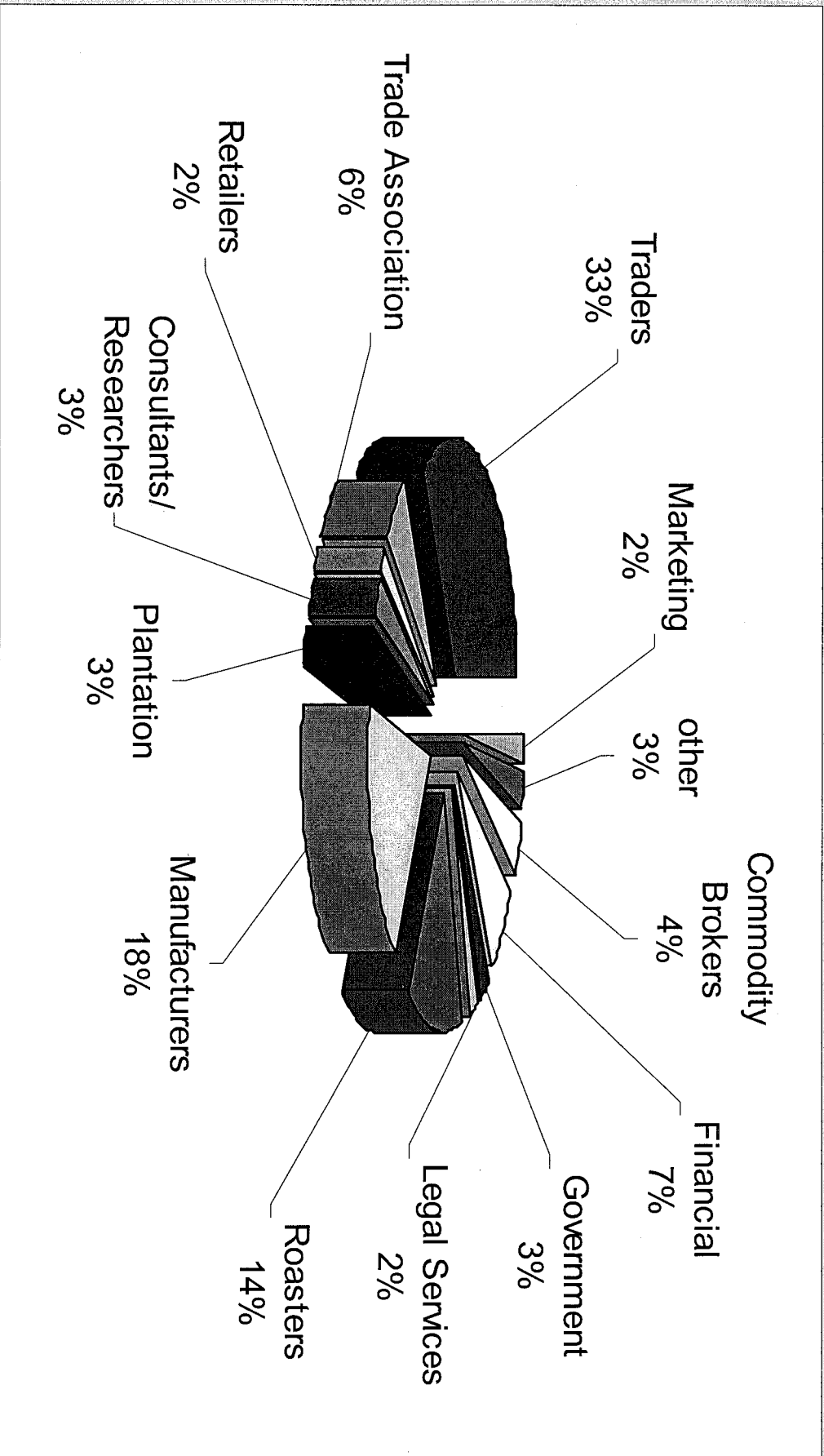

# **Exhibitors**

**ABN Amro**

**Atlas Stord**

**CAB International**

**F.O. Licht**

**IACO**

**Kraft**

**LIFFE**

**Nestlé**

**O.A.M.CAF**

**Sortex**

**Tokyo Grain Exchange**



# **Sponsors**

**Café de Colombia**

**Banco Alemán Platina**

**Nestlé**

**Neumann Kaffe Gruppe**

**International Coffee Organization**

**FOCCOFAFE**

**Tchibo**

**Café do Brasil**

Net Delegate Revenue	210,000
Net Spex Revenue	119,000
Costs	165,000
ICO	15,000

***'Very Informative,  
addressed issues  
that are very  
serious to World  
Coffee Production  
and Consumption  
and therefore  
prices?'***

**Leslie D. Omare,  
Tanzania Coffee  
Board**



***'Well chosen themes, Excellent speakers,  
Good atmosphere, should be repeated'***  
**Jose A Buitreggo, Cafenz, Nicaragua**

***'The issues were  
my main concern  
and many  
proposals were  
realistic'***  
**Mrs Balde, Embassy  
of Cote d' Ivoire**

***'I have never been  
to a conference that  
has such a  
distinguished and  
interesting line up  
of speakers'***

**Karen St Jean-  
Kufuor, ACP/C, UK**

***'Good Content Excellent Participation'***  
V Balaraman, Hindustan Lever Ltd, India

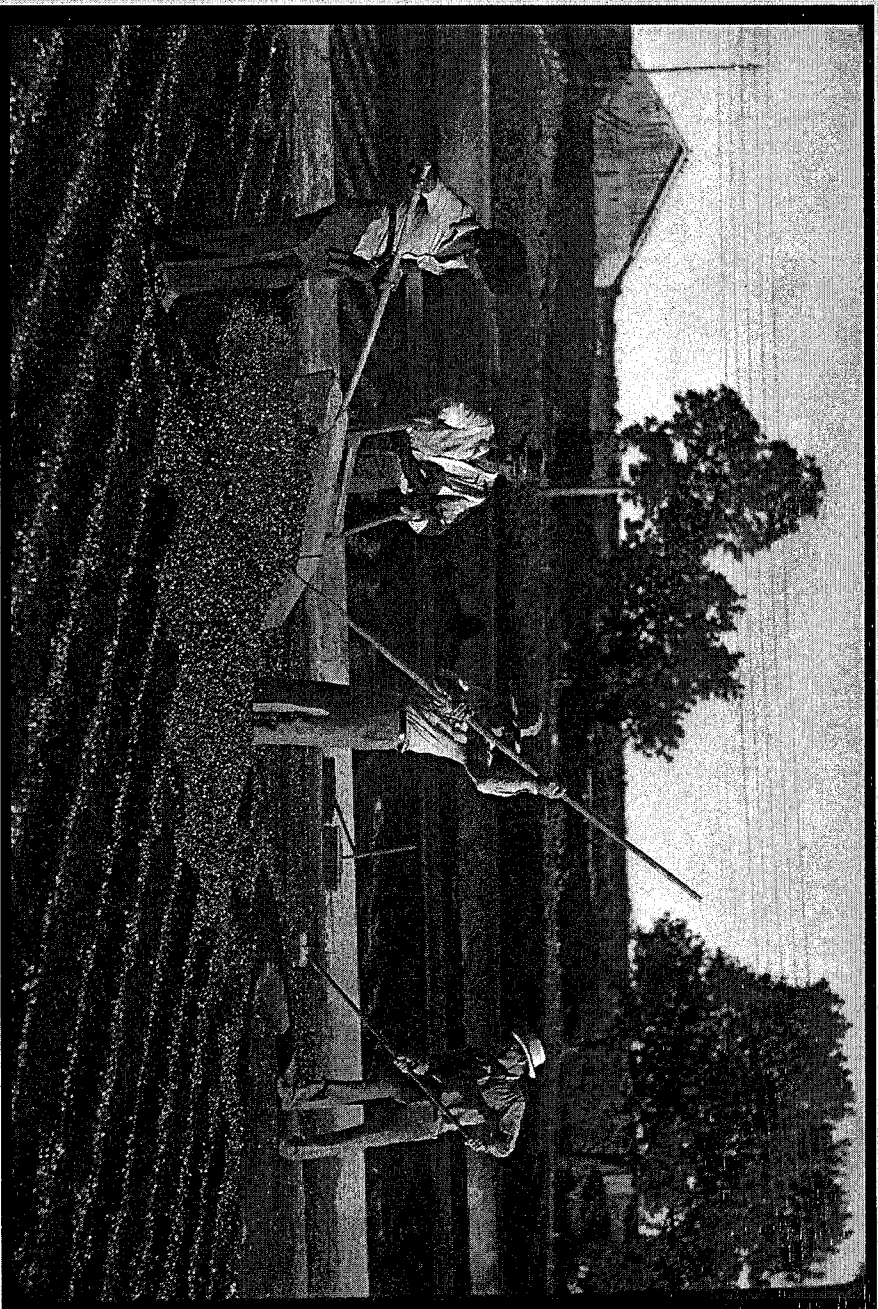

***'Excellent Content & Speakers'***  
Gerald Baldwin, Director, Peets Coffee & Tea, USA

***'Great effort to bring all of the coffee actors together at trying to attack the criticism through mutual co-operation'***  
Ernesto Sol, Consejo Salvadoreño del Café, El Salvador

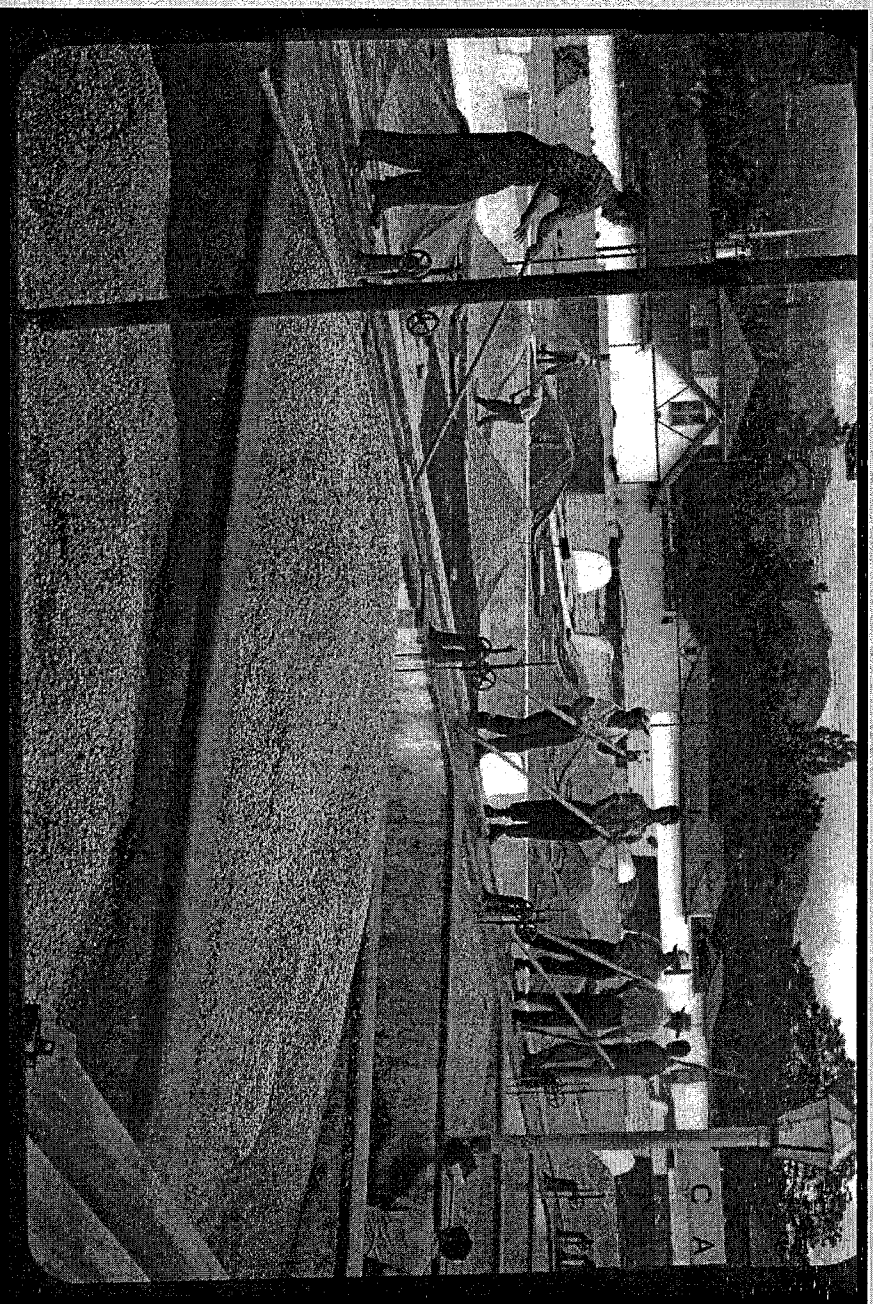

***'The conference clearly demonstrated that tariff barriers to value added coffee was a major constraint to free trade'***  
Caleb Dengu,  
Common Fund  
for Commodities,  
Netherlands

***'The attendance is marvellous, the presentations did well and the topics were fantastic'***  
SPIKA, Ministry of Commerce, Nigeria

***'One of the best  
conferences I have  
ever attended'***

Francisco Jurado,  
Nestlé Espana

***'A great  
opportunity to  
listen to the best  
speakers of the  
coffee industry'***

Aernando de la  
Roche, Director,  
Hencorp Coffee  
Group, USA

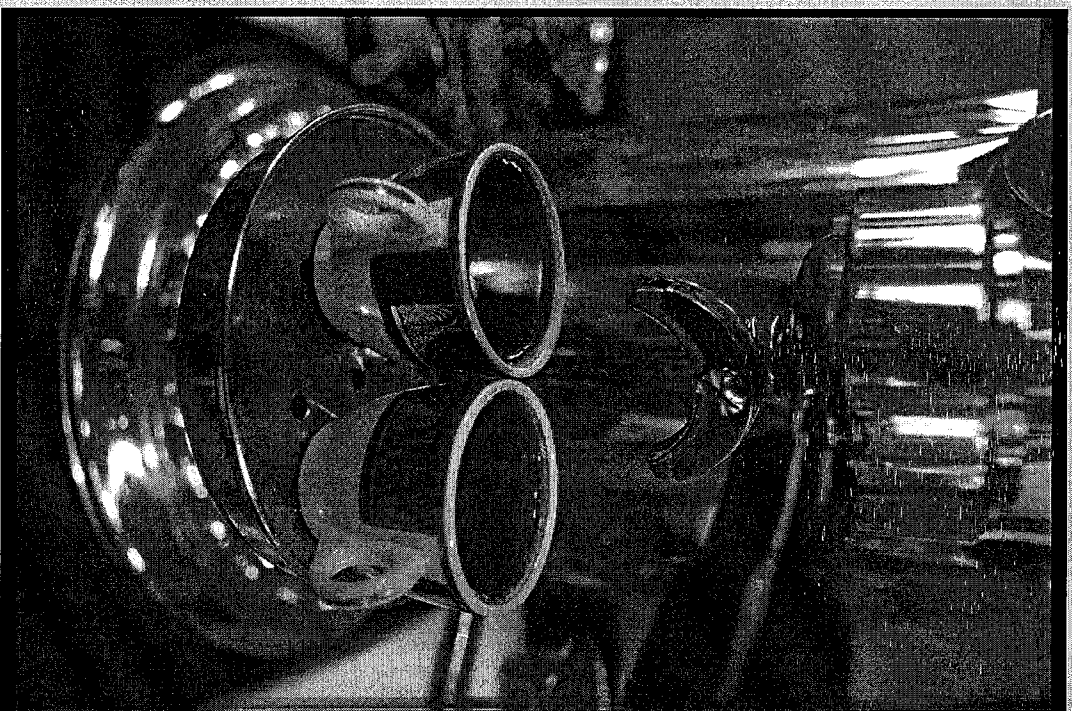

***'A distinguished  
gathering of a  
wide range of  
coffee interests  
from around the  
globe at a very  
critical phase in  
the coffee  
industry.'***

Lakstim  
Venkatatcha,  
Coffee Board of  
India

***'Very much needed forum – Needs follow up actions'***

Douglas Burns, Kraft Foods

# When to hold the next World Coffee Conference?

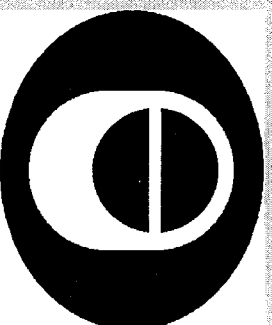

<b>World Coffee 2003:</b>	<b>61%</b>
<b>World Coffee 2004:</b>	<b>39%</b>

**FOLICHTS**